

Characteristics:

High efficient, Energy saving, Long life, Low noise

Specifications:

Shaft Diameter	: Ø 0.315 in
Input Voltage	: 120.0 V AC
Output Power at Maximum Efficiency	: 0.24 hp
Maximum Efficiency	: 81%
Torque at Maximum Efficiency	: 5.22 lb.in
Speed at Maximum Efficiency	: 2880 rpm
Weight	: 78 oz
Electrcial Connection	: Y to Connection

**Performance Data:**

	No Load	Stall	Maximum Efficiency	Maximum Power
Current (A)	0.30	11.50	2.83	6.33
Efficiency (%)	-	-	81	57
Output Power (hp)	-	-	0.24	0.37
Speed (rpm)	3650	-	2880	1700
Torque (Lb.in)	-	26.11	5.22	13.90

Application Examples:

Range Hood Fans, Kitchen Range Hoods, Home Ventilation

Outline Drawing:

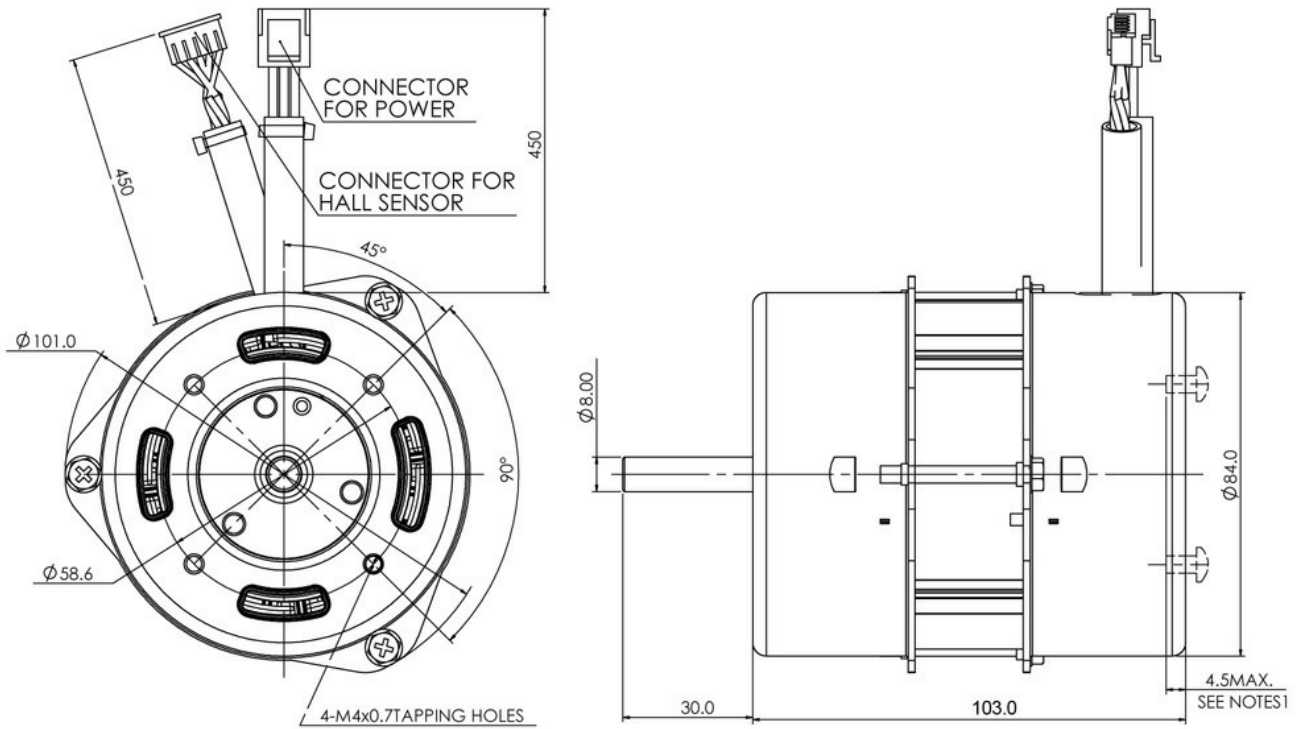

Performance Curves:

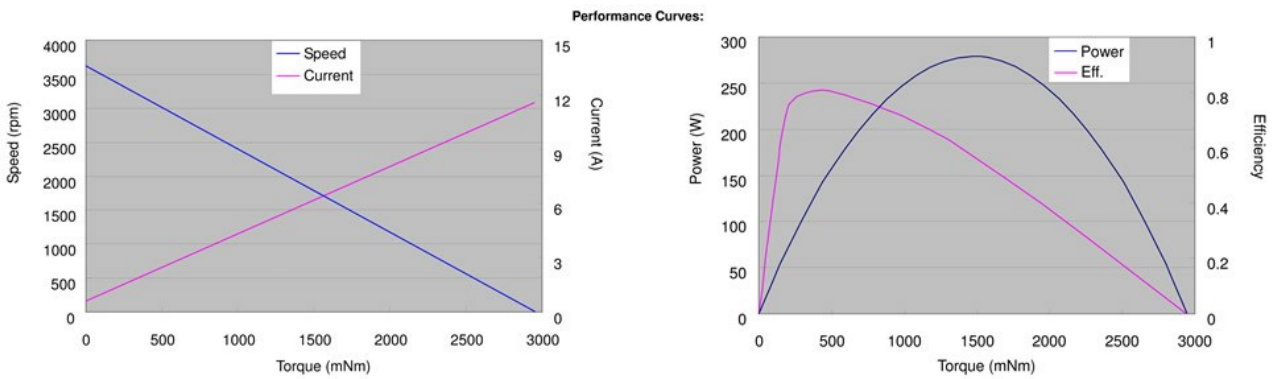

Units in Metric