

Characteristics:

Compact, low weight, low noise, low power budget

Specifications:

Dimensions	: Ø 39.8 X 29.4 X 66.8 mm
Input Voltage	: 12.0 V DC
No Load Speed	: 88.0 rpm
No Load Current	: 1.4 A
Maximum Output Power	: 17.0 W
Stall Torque	: 7.0 Nm
Life	: 20,000 cycles
Weight	: ~ 450 g
Operation Temperature	: -40 to 85 °C
Storage Temperature	: -40 to 100 °C
Certification	: RoHS



Performance Data:

	No Load	Stall	Max Eff	Max Power
Speed (rpm)	88.0	-	69.0	45.0
Current (A)	1.4	16.2	4.8	8.8
Torque (Nm)	-	7.0	1.7	3.7
Output Power (W)	-	-	12.0	17.0

Application Examples:

Window Lift Drives

Drawing:

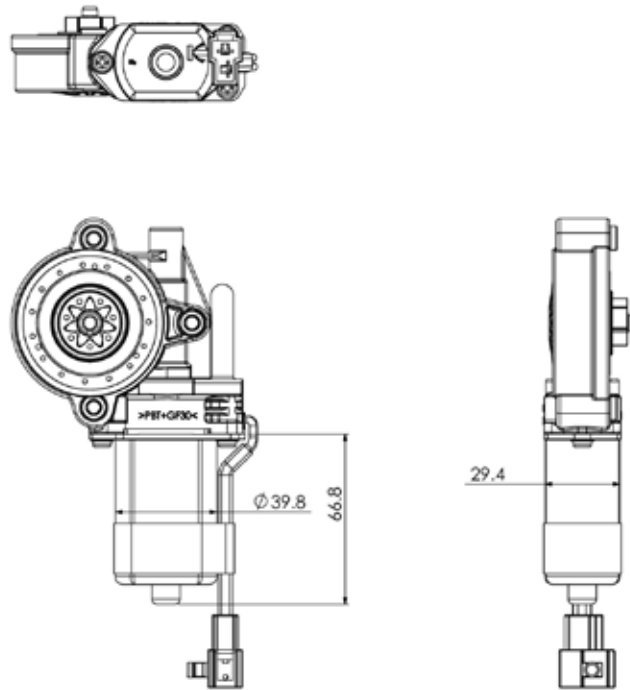

Unit in mm

Performance Curve:

