

Characteristics:

Compact, low weight, low noise, low power budget

Specifications:

| | |
|-----------------------|---------------------------|
| Dimensions | : Ø 39.8 X 29.4 X 66.8 mm |
| Input Voltage | : 12.0 V DC |
| No Load Speed | : 92.0 rpm |
| No Load Current | : 1.7 A |
| Maximum Output Power | : 22.0 W |
| Stall Torque | : 9.0 Nm |
| Life | : 20,000 cycles |
| Weight | : ~ 450 g |
| Operation Temperature | : -40 to 85 °C |
| Storage Temperature | : -40 to 100 °C |
| Certification | : RoHS |



Performance Data:

| | No Load | Stall | Max Eff | Max Power |
|------------------|---------|-------|---------|-----------|
| Speed (rpm) | 92.0 | - | 72.0 | 47.0 |
| Current (A) | 1.7 | 20.5 | 5.9 | 11.0 |
| Torque (Nm) | - | 9.0 | 2.0 | 4.5 |
| Output Power (W) | - | - | 15.0 | 22.0 |

Application Examples:

Window Lift Drives

Drawing:

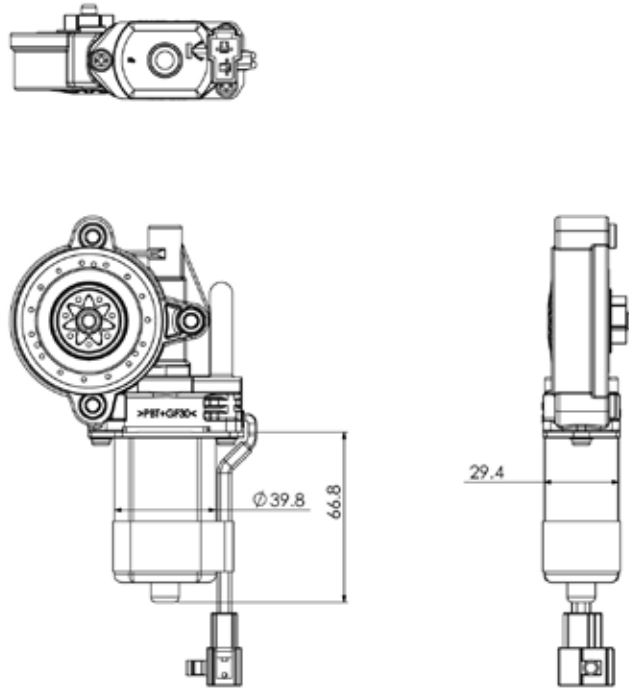

Unit in mm

Performance Curve:

