

Characteristics:

Compact, low weight, low noise, low power budget

Specifications:

Dimensions	: Ø 39.8 X 73.5 X 29.4 mm
Input Voltage	: 13.0VDC
No Load Speed	: 77.0 rpm
No Load Current	: 1.2 A
Maximum Output Power	: 22.3 W
Stall Torque	: 11.2 Nm
Life	: 20,000 cycles
Weight	: ~520 g
Operation Temperature	: -40 to 80°C
Storage Temperature	: -40 to 100°C
Certification	: RoHS

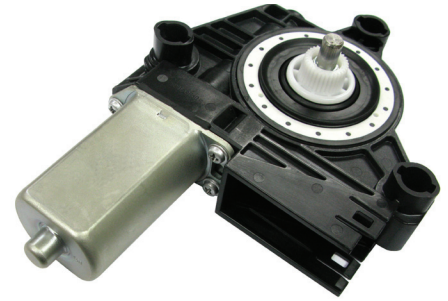

Performance Data:

	No Load	Stall	Max Eff	Max Power
Speed (rpm)	77.0	-	61.0	38.0
Current(A)	1.2	20.8	4.9	11.0
Torque(Nm)	-	11.2	2.1	5.6
Output Power(W)	-	-	13.8	22.3

Application Examples:

Window Lift Drives

Drawing:

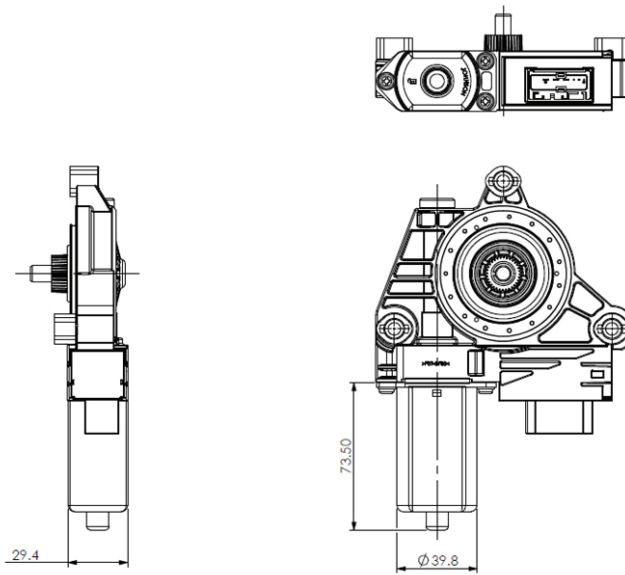

Unit in mm

Performance Curve:

